

1125 PIR Motion Detector

Description

The 1125 PIR (Passive Infrared) Motion Detector is a wireless, low current sensor for use with DMP Wireless Receivers. Using mirrored optic technology the 1125 PIR is highly immune to multiple false alarm sources. In addition to switch-selectable sensitivity and range adjustment, you can use masking to modify coverage patterns for various applications.

Compatibility

All DMP 1100 Series Wireless Receivers and Panels

What is Included

The 1125 PIR Motion Detector includes the following items:

- One PIR detector with DMP wireless transmitter installed
- Three CR123A 3.0V lithium batteries
- Two plastic masks
- One screw to secure the unit to the wall mounting bracket
- One wall-mounting bracket
- One sheet of adhesive masking labels
- One cardboard undercrawl window mask
- Zone name and number label
- Serial number label

Transmitter Serial Number

For your convenience, an additional pre-printed serial number label is included. Prior to installing the device, record the serial number or place the pre-printed serial number label on the panel programming sheet. This number is required during programming. As needed, use the zone name and number label to identify a specific transmitter.

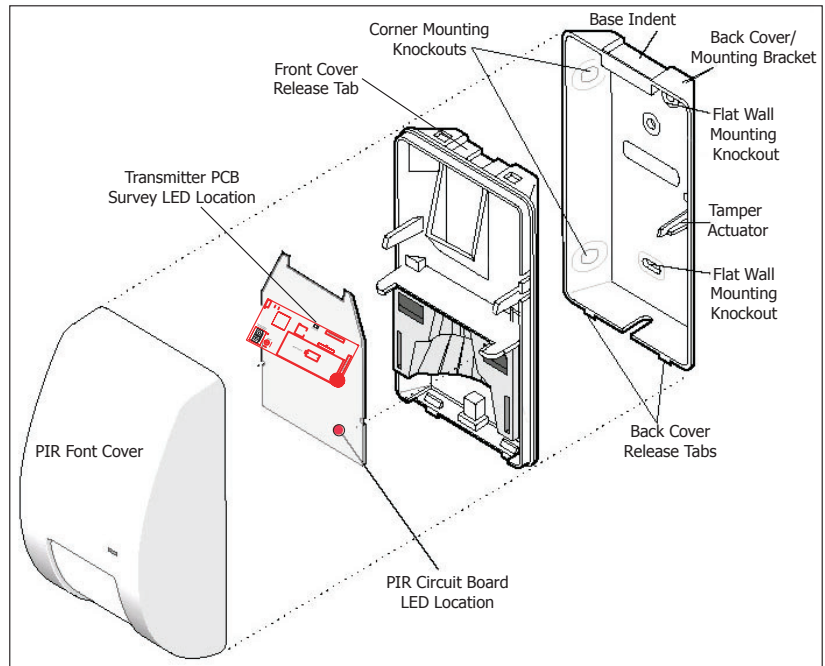

Figure 1: 1125 PIR Exploded View

Programming the PIR in the Panel

Refer to the XR500 Series Programming Guide (LT-0679), XR100 Series Programming Guide (LT-0896), XT30/XT50 Series Programming Guide (LT-0981), or the XRSuper6/XR20/XR40 Programming Guide (LT-0305) as needed. Program the device as a zone in **Zone Information** during panel programming. At the Serial Number: prompt, enter the eight-digit serial number. Continue to program the zone as directed in the panel programming guide.

Note: When a receiver is installed, powered up, or the panel is reset, the supervision time for transmitters is reset. If the receiver has been powered down for more than one hour, wireless transmitters may take up to an additional hour to send a supervision message unless tripped, tampered, or powered up. This operation extends battery life for transmitters. A missing message may display on the keypad until the transmitter sends a supervision message.

Selecting the Proper Location (LED Survey Operation)

The PIR transmitter provides a survey capability to allow one person to confirm transmitter communication with the receiver while the cover is removed. Refer to Figure 1 and the PIR Walk Test steps to remove the PIR front cover. The PIR transmitter PCB Red Survey LED turns on when the processor wakes up to send a message. Then after a series of communication steps are completed (successful or not), the LED turns off when the processor goes back to sleep. Waving your hand in front of the PIR is a convenient way to send data to the receiver to confirm operation. The PIR circuit board LED lights to indicate motion and the Survey LED briefly lights to confirm operation. See Figure 1 for LED locations.

When the transmitter does not receive an acknowledgement from the receiver, the transmitter Survey LED remains on for about 8 seconds to let you know communication is not established. Communication is also faulty when the LED flashes multiple times in quick succession. Relocate the transmitter or receiver until the Survey LED immediately turns off indicating the transmitter and receiver are communicating properly. Proper communication between the transmitter and receiver is verified when for each hand wave that creates motion, the LED blinks immediately on and immediately off. Repeat this test to confirm five separate consecutive LED blinks. Any indication otherwise means proper communication has not been established.

PIR Walk Testing

A Walk test Mode for testing the unit operation and coverage pattern is provided. Use the following instructions to take the PIR apart and walk test the unit:

1. Ensure the 1125 PIR is programmed in the Command Processor™ panel.
2. Use a flat head screwdriver to press the back cover tabs to release the back cover and open the tamper switch to enable the Walk test Mode.
3. Press the front cover release tab to remove the front cover to access the Transmitter and PIR circuit boards.
4. When the unit is remounted on the bracket, the Walk test Mode is enabled for 3-4 minutes. If additional time is required, depress and release the tamper switch to reset the Walk test timer. Depending on switch settings (see Selecting the Coverage Pattern), the Walk test Mode allows the unit to alarm whenever one or two curtain areas are entered. The LED visible on the front cover lights to indicate an alarm.
5. Walk test the detection pattern and make any necessary adjustments.
6. Replace and walk test the unit to verify the unit is communicating with the control panel.

Note: After Walk test Mode times out (3 to 4 minutes), the unit returns to normal operating mode. In normal operating mode, the PIR unit only activates approximately once every three minutes, and the LED disables to reduce battery drain.

Mounting the Unit



Caution: You must be free of static electricity before handling sensor circuit boards. Touch a grounded, bare metal surface before touching circuit boards or wear a grounding strap.

Locate the unit:

- On a rigid vibration-free surface
- 6 to 10 feet (1.8 to 3m) high, but at least 6 inches (15cm) from the ceiling
- So the expected intruder movement is across the detection pattern fields, see Figure 2

Do not locate the unit:

- On a surface exposed to moisture
- In any area containing excessive metallic surfaces
- Where it may be exposed to false alarm sources such as: direct sunlight, heat sources (heater, radiators, etc.) in the field of view or strong air drafts (fans, air conditioner, etc.)
- Where the ambient temperature is below 32° F (0° C) or above 131° F (55° C)

Use the following steps to mount the PIR in the selected location.

1. Separate the PIR unit from the mounting bracket. Refer to Figure 1 for details.
2. Insert a small flat-head screwdriver between the tabs at the unit bottom and turn the screwdriver to push the tabs apart.
3. Select the appropriate knockout mounting holes on the mounting bracket for either corner or flat wall mounting.

Note: Holes near the tamper actuator are not mounting knockouts.

4. Use screws and wall anchors, if necessary, to attach the mounting bracket to the wall. Do not over-tighten.
5. Snap the unit to the mounting bracket.

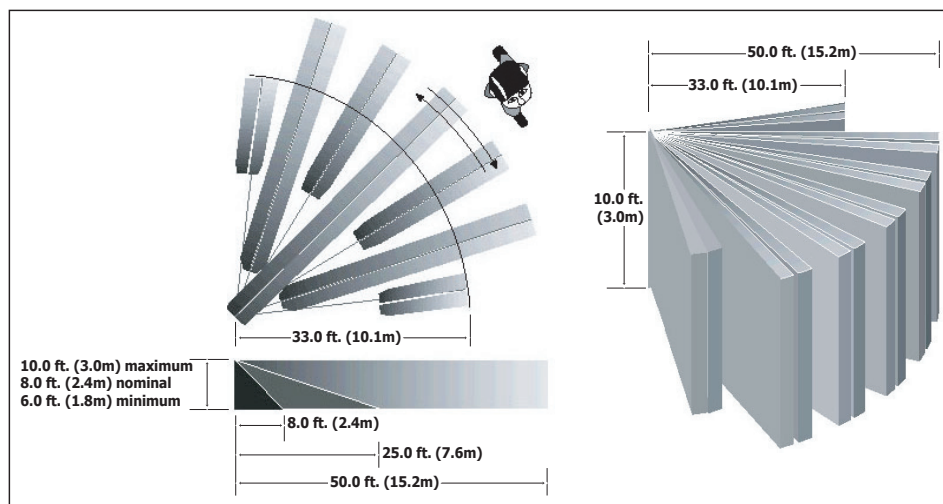

Figure 2: Detection Pattern

Selecting the Coverage Pattern

The unit coverage pattern can be modified to fit specific applications by masking mirror curtains. Mask curtains to avoid sources of false alarms, such as heaters, air conditioners, and windows. Open the unit by pushing the opening tab up. If necessary, use one or more of the following methods to modify the coverage pattern.

Using the plastic masks

Use one or both of the plastic masks provided to mask off large coverage areas as shown in Figure 3.

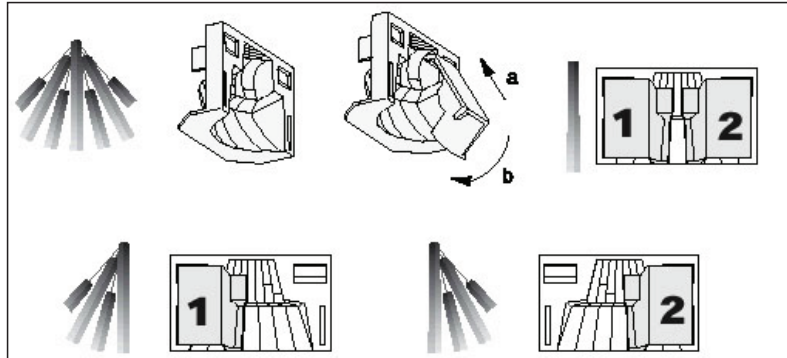

Figure 3: Plastic Masks

Using the adhesive labels

Mask the appropriate mirror curtains with the provided adhesive labels. See the example shown in Figure 4. Do not use sharp objects to remove unwanted labels. If necessary, carefully peel off the label.

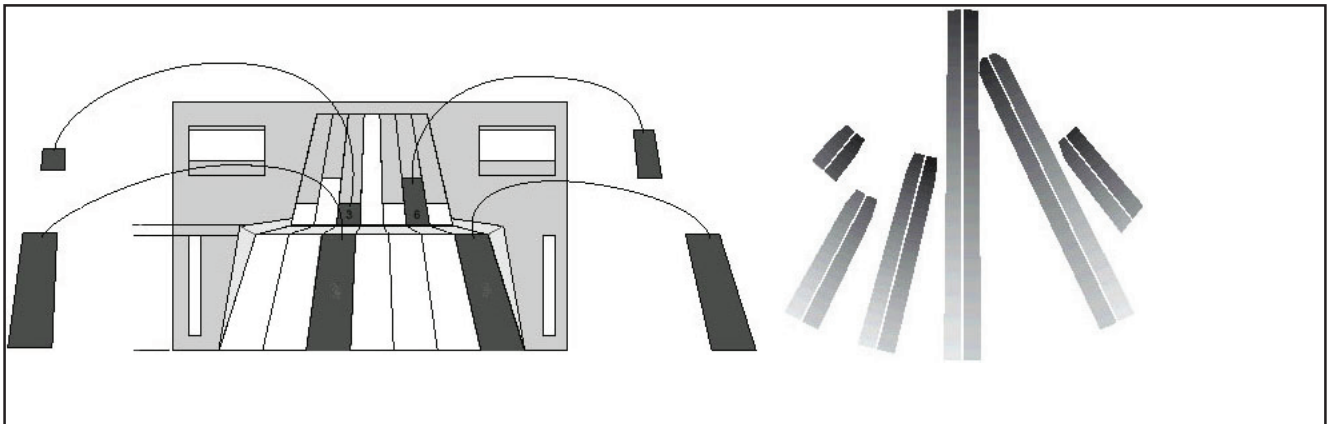

Figure 4: Adhesive Labels

Using the cardboard masks

Use the cardboard undercrawl window mask as shown in Figure 5. The undercrawl mask allows objects to be placed within 5 feet of, or directly below, the detector. When not using the mask as described here or in the Pet Alley configuration, remove the mask completely.

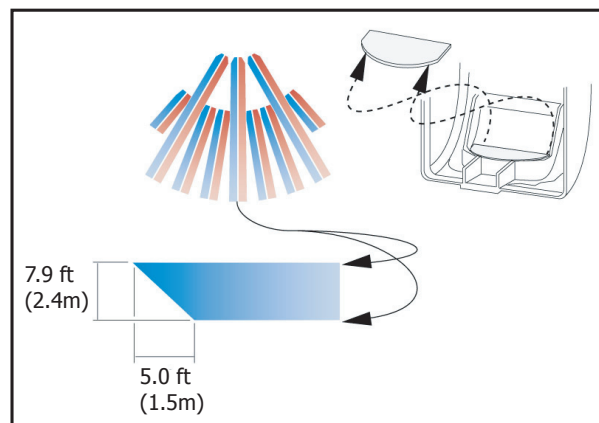

Figure 5: Cardboard Masks

Setting the Sensitivity and Range Switches

Use the switches located on the unit back to set sensitivity and range, as shown in Figure 6. Use the following to determine the appropriate switch settings for an application.

Mode

BI = Bi-curtain Mode (factory default) increases false alarm immunity in smaller areas and requires an intruder to pass through two curtains to trigger an alarm. Do not use for single curtain applications or ranges under 5 feet (1.5 m).

STD = Standard Mode is used for wide-angle or single-curtain applications. This requires the intruder to only pass through one curtain to trigger an alarm.

Range

Program the switch for a range under 33 feet (10.1 m) or up to 50 feet (15.2 m). It is important to program the unit correctly for optimum sensitivity. Walk test the unit regularly by walking across the fields of view and checking that the LED lights and that an alarm is indicated at the control panel. See Walk Testing.

Note: The PIR LED only lights if the unit is placed in Walk test Mode by the installer. See PIR Walk Testing.

Installing or Replacing Batteries

Note: You must remove all batteries to reset the low battery signal before installing new batteries. Always replace all three batteries. Allow three minutes after installing the batteries for the sensor to become operational before initiating a Walk Test.

Observe polarity when installing the battery. Use only 3.0V lithium batteries, DMP Model CR123, or the equivalent battery from a local retail outlet. For UL installations, only use #123 batteries manufactured by Energizer or CR123A batteries manufactured by Panasonic or Tekcell.

Note: When setting up a wireless system, it is recommended to program zones and connect the receiver before installing batteries in the transmitters.

1. If installed, remove the PIR back cover.
2. If replacing the batteries, remove the old batteries and dispose of them properly.
3. Place the 3.0V lithium batteries in the holder as shown in Figure 6 and press each one into place.



Caution: Risk of fire, explosion, and burns. Do not recharge, disassemble, heat above 212°F (100°C), or incinerate. Properly dispose of unused batteries.

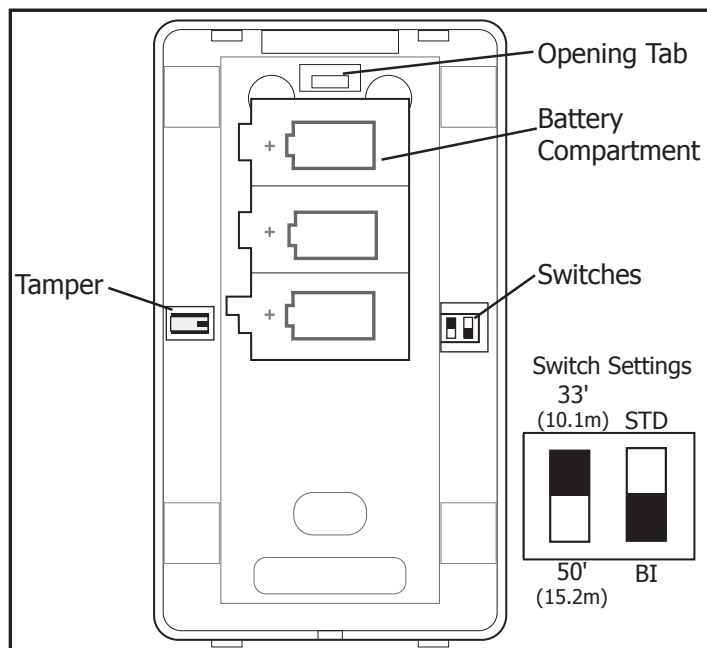

Figure 6: 1125 PIR Switches

Battery Life Expectancy

Typical battery life expectancy for DMP Model 1125 wireless PIR is 7 years when using three batteries. DMP wireless equipment uses two-way communication to extend battery life.

The following situations can reduce battery life expectancy:

- If a receiver is unplugged or not installed.
Note: Transmitters continue to send supervision messages until a receiver returns an acknowledgement. After an hour the transmitter only attempts a supervision message every 60 minutes.
- Frequent transmissions, such as constant motion where messages are sent every time the movement is detected. To compensate for frequent motion, the 1125 PIR automatically rests for three minutes after each activation before any further motion can be detected.
- When installed in extreme hot or cold environments.

The following situation can extend battery life expectancy:

- Extend transmitter supervision time in panel programming.
- Infrequent transmission trips, such as a low traffic area where messages are rarely sent.

Maintenance

When installed and used properly, the unit provides years of service with minimal maintenance. To ensure proper operation, you should walk test the unit annually as described in Walk Testing. Clean the inside of the unit with a soft bristled brush or compressed air. Clean the cover with a water dampened cloth as needed to keep it free of dust and dirt. Always test the unit after cleaning.

Pet Alley Application

To create a detection-free area close to the floor, mount the unit 3 feet (0.9 m) above the floor, upside down with the detector window toward the ceiling. The undercrawl mask should be in place to reduce ceiling exposure. Coverage distance is 25 feet in Bi-curtain Mode. As shown in Figure 7, pets are free to roam below the unit mounting height without causing alarms. When not using the mask as described here or in the Using the cardboard masks configuration, remove the mask completely.

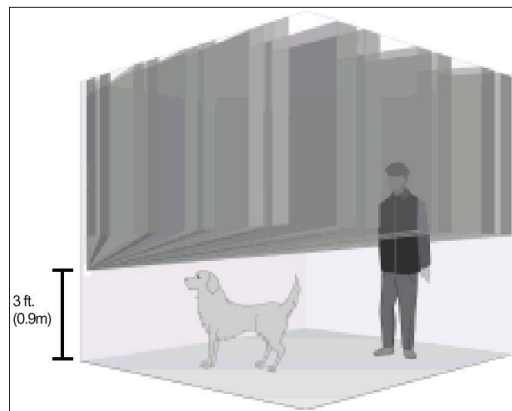

Figure 7: Pet Alley

FCC Information

This device complies with Part 15 of the FCC Rules. Operation is subject to the following two conditions:

- (1) This device may not cause harmful interference, and
- (2) this device must accept any interference received, including interference that may cause undesired operation.

The antenna used for this transmitter must be installed to provide a separation distance of at least 20 cm from all persons. It must not be co-located or operated in conjunction with any other antenna or transmitter.

Changes or modifications made by the user and not expressly approved by the party responsible for compliance could void the user's authority to operate the equipment.

NOTE: This equipment has been tested and found to comply with the limits for a Class B digital device, pursuant to part 15 of the FCC Rules. These limits are designed to provide reasonable protection against harmful interference in a residential installation. This equipment generates, uses and can radiate radio frequency energy and, if not installed and used in accordance with the instructions, may cause harmful interference to radio communications. However, there is no guarantee that interference will not occur in a particular installation. If this equipment does cause harmful interference to radio or television reception, which can be determined by turning the equipment off and on, the user is encouraged to try to correct the interference by one or more of the following measures:

- Reorient or relocate the receiving antenna.
- Increase the separation between the equipment and receiver.
- Connect the equipment into an outlet on a circuit different from that to which the receiver is connected.
- Consult the dealer or an experienced radio/TV technician for help.

Specifications

Battery	
Life Expectancy	7 years using 3 batteries
Type	3.0V lithium CR123A
	See Battery Life Expectancy for details.
Transmit condition	Alarm, tamper
Frequency Range	903-927 MHz
Detection range	Up to 50 feet (15.2 m)
Mounting height	6 to 10 feet (1.8 to 3m)
Number of curtains	9
Relative humidity	10 to 85% non-condensing
Dimensions	5.1" H X 2.9" W X 2.2" D
Color	White
Housing material	Flame retardant ABS

Patents

U. S. Patent No. 7,239,236

Listings and Approvals

FCC Part 15 Registration ID CCKPC0088

IC Registration ID 5251A-PC0088

Underwriters Laboratories (UL) Listed

ANSI/UL 1023 Household Burglar Alarm System Units
Accessory

ANSI/UL 639 Intrusion Detection Unit Accessory



Digital Monitoring Products

800-641-4282

www.dmp.com

Made in the USA

INTRUSION • FIRE • ACCESS • NETWORKS

2500 North Partnership Boulevard

Springfield, Missouri 65803-8877

LT-0695 © 1.01 2009 Digital Monitoring Products, Inc.

9171

